

NL-ECO-RH

Relative humidity room sensor



User manual

Description	The sensor is used for continuous monitoring of relative humidity in the room and for efficiently controlled ventilation.		
Usage	Homes, bathrooms, restrooms, offices, schools, shops, shopping centres, restaurants, food stores, waiting rooms, dressing rooms		
Key features	<ul style="list-style-type: none"> — Optical air quality indication — Night mode – LEDs turn off automatically at night — Long-term durability and stability — Voltage output 0 – 10 V DC — Relay switch contact – adjustable relay switching level 		
Technical specifications	— Monitored variable	RH (Relative Humidity)	% RH
	— Range	0 – 100	% RH
	— Accuracy (0 – 90 % RH)	± 4	% RH
	— Accuracy (0 – 100 % RH)	± 5	% RH
	— Voltage output	0 – 10	V DC
	— Relay switch contact	max. 250 / 30	V AC / V DC
	— Switching current	max. 5	A AC / DC
	— Supply voltage	12 – 24	V AC / DC
	— Maximum power input ¹⁾	< 1	W
	— Expected lifetime	min. 10	years
	— Operating temperature	0 – 50	°C
	— Operating humidity ²⁾	5 – 95	% RH
	— Degree of protection	IP20	-
	— Storage temperature	-20 to 60	°C
	— Dimensions	90 x 80 x 31	mm

1) With the relay on and the voltage output loaded with a 1 kOhm resistor

2) Non-condensing

Recommended sensor location

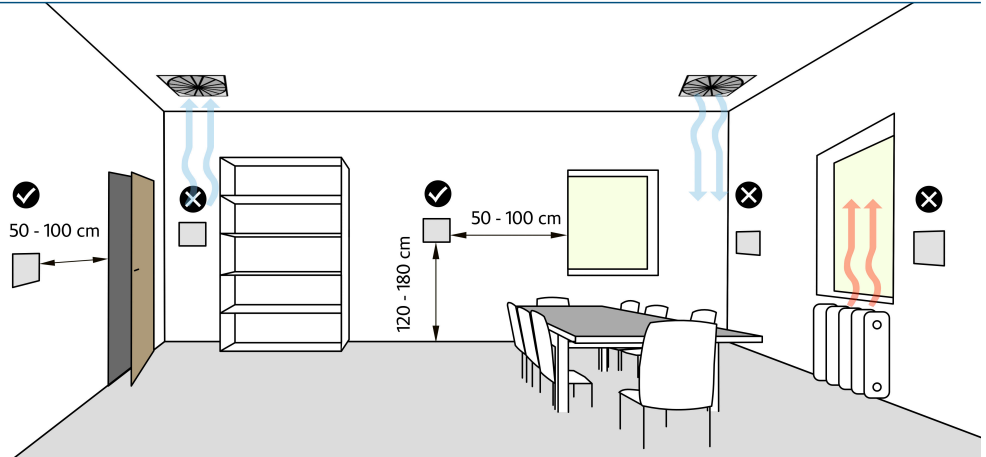

- At a sufficient distance from the source of the draught
- Ensure sufficient space around the sensor
- In principle, the same rules apply as for the positioning of the room temperature sensor or thermostat

Opening the sensor

1

Squeeze the plastic latches with the appropriate size flathead screwdriver at the top of the sensor.

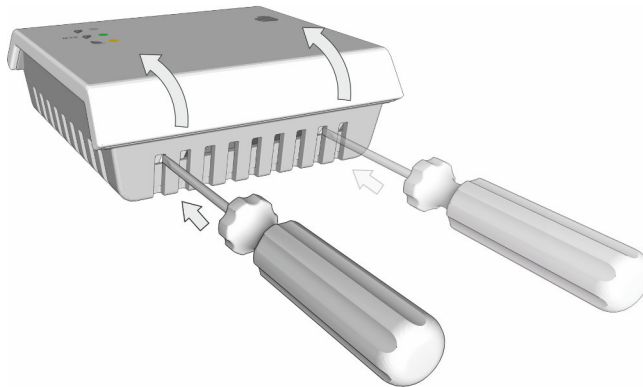

2

Tilt the front part outwards.

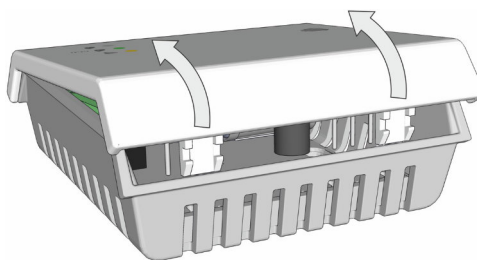

RH measuring range

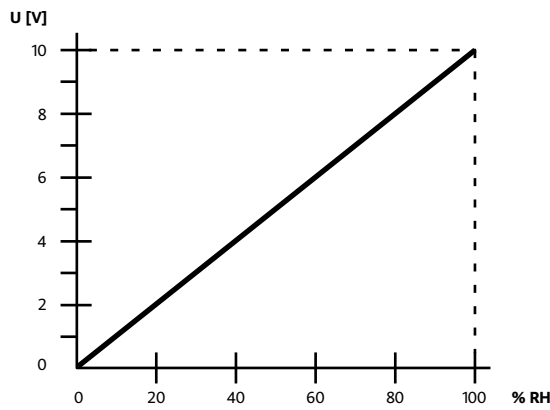

Setting the relay switching level

Adjustment is made using the rotary selector, from 0 – 100% of the RH sensor range, see switching example below.

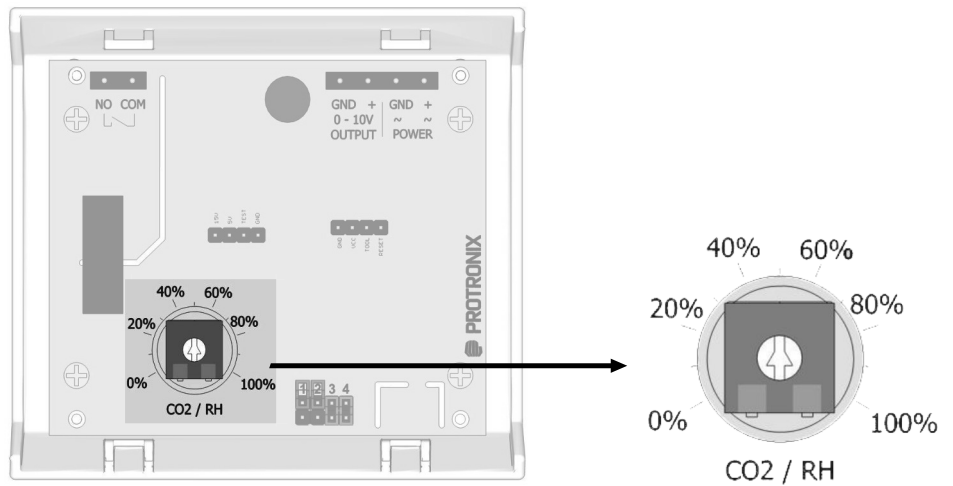

Set value	RH %
0 %	0
10 %	10
20 %	20
30 %	30
40 %	40
50 %	50
60 %	60
70 %	70
80 %	80
90 %	90
100 %	100

Hysteresis – Hysteresis is always 5% of the range.

Example of relay switching – RH setpoint is 50 %.
Minimum delay between switching of the relay is 2 minutes.

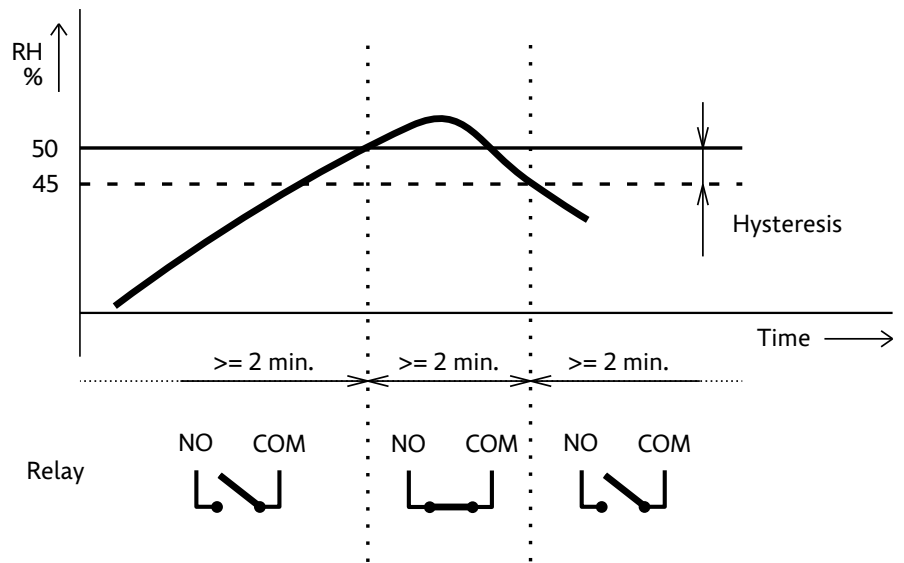

LED indicator lights

The sensor is equipped with a three-stage optical indication of the current humidity level.

- Orange — > 60 % RH

High humidity. Risk of mold growth and associated health complications.
- Green — 40 – 60 % RH

Optimum humidity for a comfortable living environment.
- White — < 40 % RH

Low humidity. Dry air feels colder than high humidity despite being the same temperature. Dryness of mucous membranes – respiratory problems.

Choice of LED indication

Using the J3/2 short-circuit jumper, it is possible to select automatic LED switching off at night or permanent indication mode.

LED indication	Jumper J3/2
Automatic dimming at night	<p>1 2 3 4</p>
LED ON permanently	<p>1 2 3 4</p>

Sensor power up

When the power supply is connected, all LEDs will flash – signaling power on/reset of the sensor. Then according to the current humidity the white, green or orange LED lights up for about within 10 seconds – sensor initialization

– All LEDs lit: sensor internal error.

Factory default sensor settings

Relay switching level	50 %
LED indication	automatic dimming at night

Electrical wiring

The supply wires are plugged into the terminals fixed in the bottom of the plastic sensor box.

The sensor electronics are located at the top of the box, which connects to the supply wires in the terminal box by means of contact studs after the top of the sensor has been inserted into the bottom of the box.

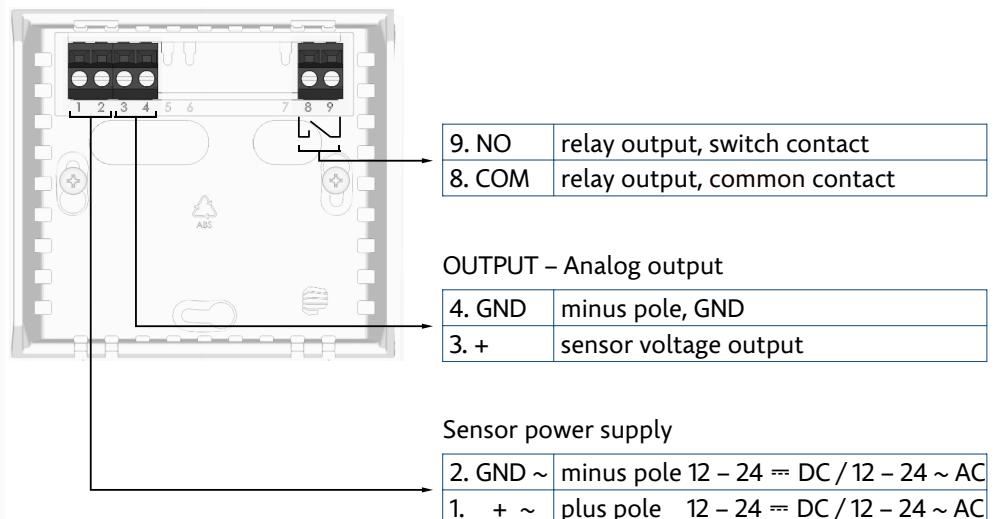

Sensor wiring examples

- connection to a conventional heat recovery unit with control input 0 – 10 V
- power supply of the sensor from the control electronics of the heat recovery unit

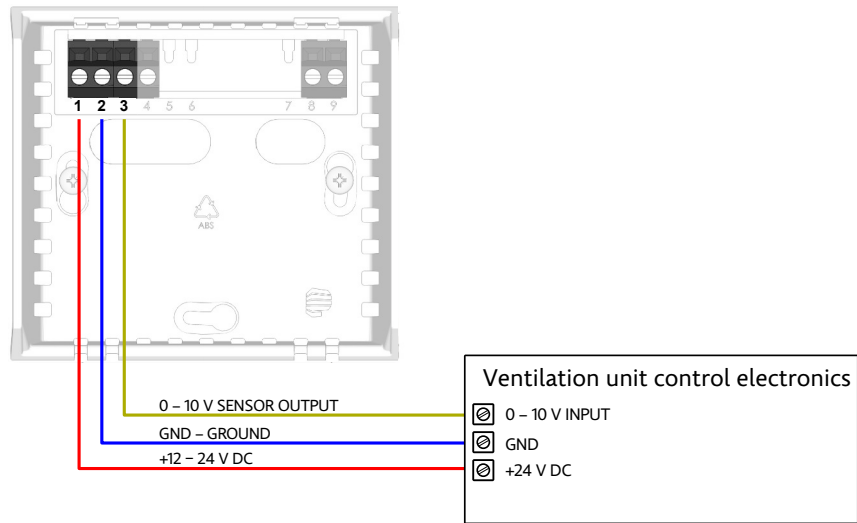

- connection of a 0 – 10 V signal combiner from multiple sensors to the 0 – 10 V control input recuperation units
- power supply from the control electronics of the heat recovery unit.

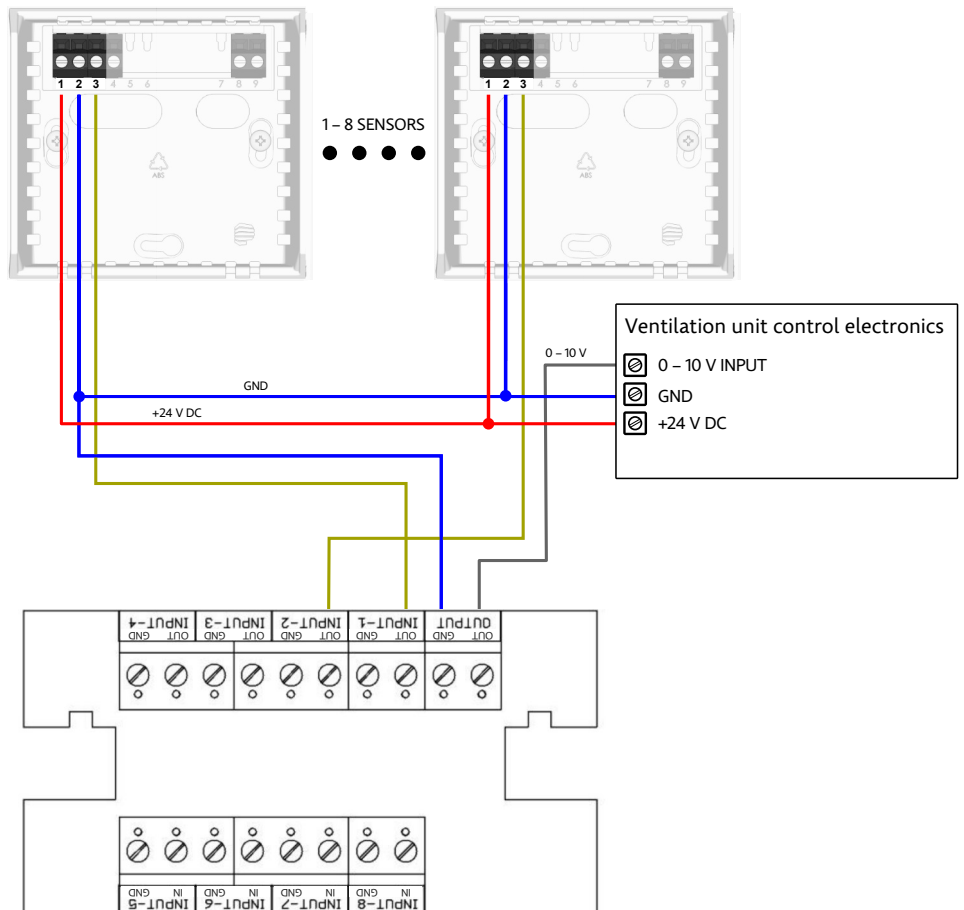

- direct EC motor control by 0 – 10 V sensor output
- DC power supply

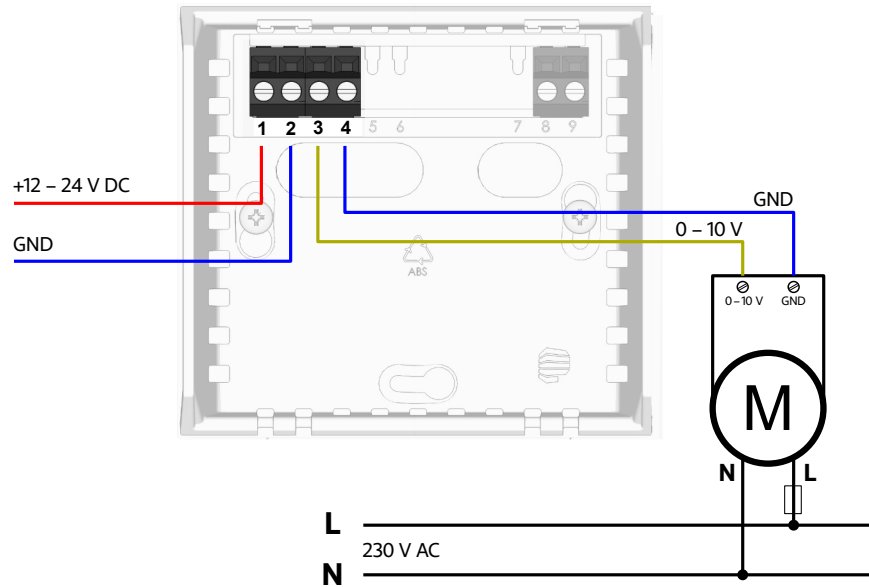

- direct switching of the fan by the sensor using the relay switching contact
- DC power supply

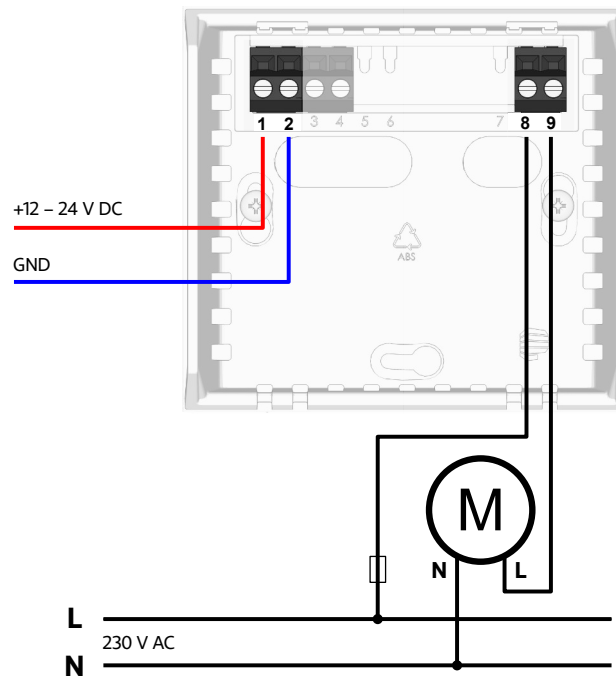

Wiring examples

- direct EC motor control by 0 – 10 V sensor output
- power supply from external AC power supply

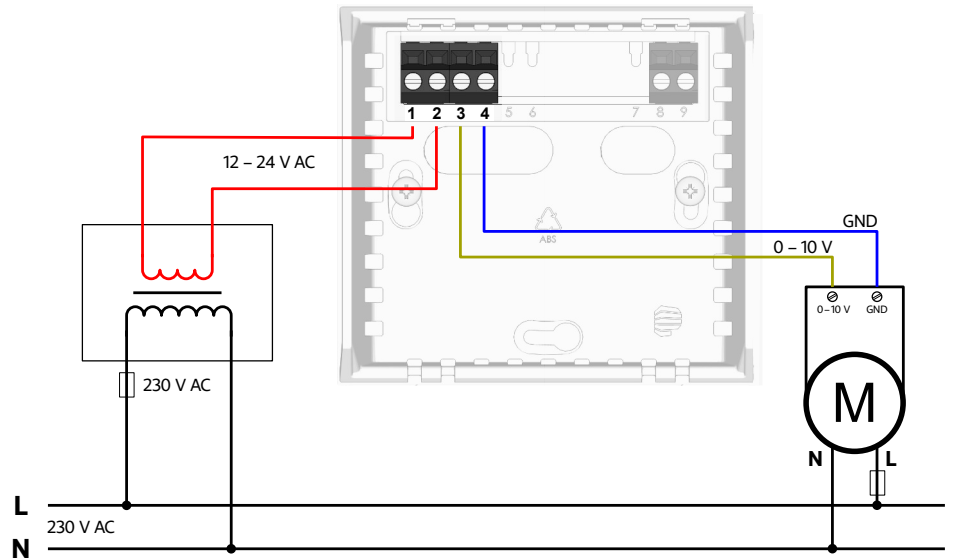

- direct switching of the fan by the sensor using the relay switching contact
- power supply from external AC power supply

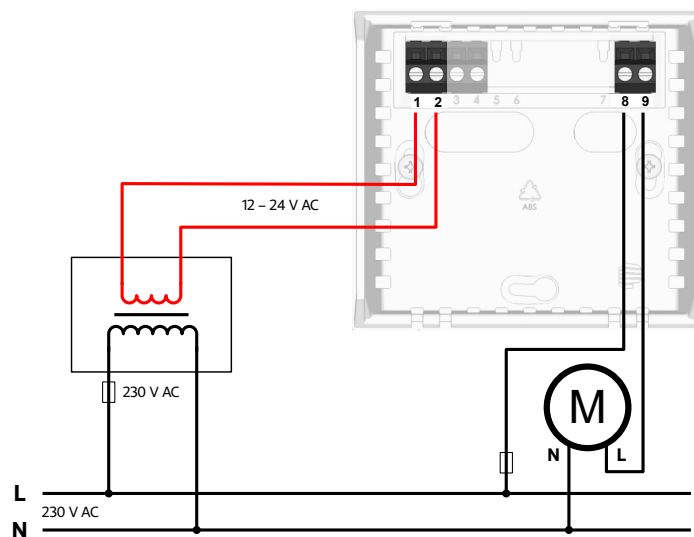

Power multiple devices from one AC power supply

If multiple sensors or other devices are connected to a common AC power supply it is necessary to maintain identical GND connection of all analog inputs and outputs as well as power supply wires! Since one pole of the power supply (2nd GND~) is internally connected to the GND voltage output of the sensor.

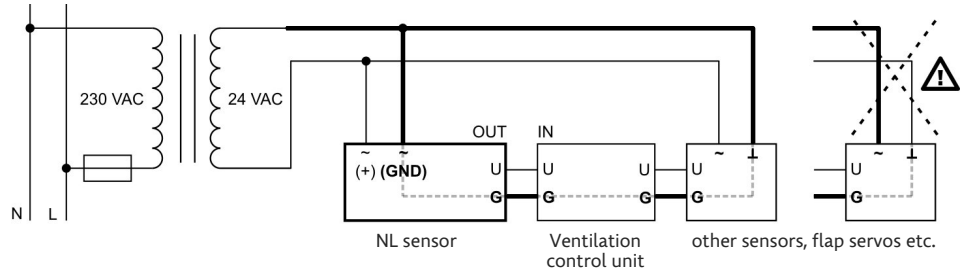

Wall mounting

The sensor can simply be screwed onto a standard concealed installation box. Screws and dowels for fixing the sensor to the wall are included.

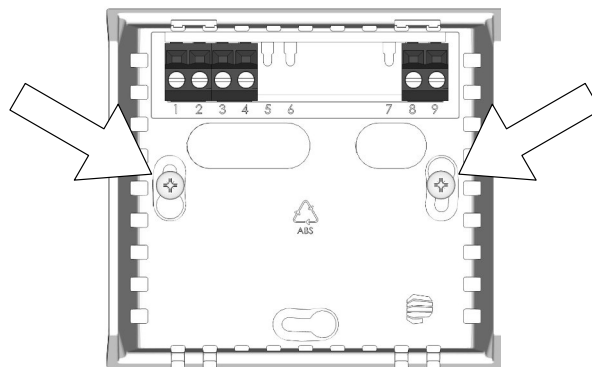

Sensor assembly

The top of the sensor must first be inserted into the plastic hinges at the bottom of the box, and then the top must be "knocked" with adequate force so that the connecting spikes fit into the corresponding clips and the two plastic latches at the top of the box fit properly into the bottom of the box.

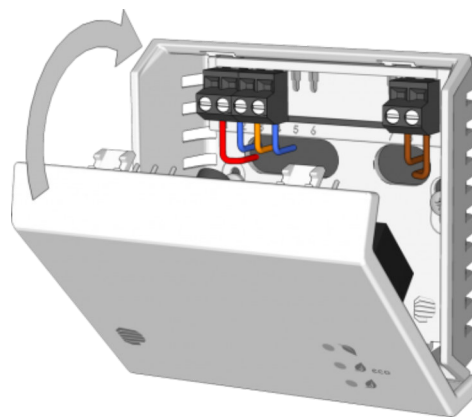

Dimensions

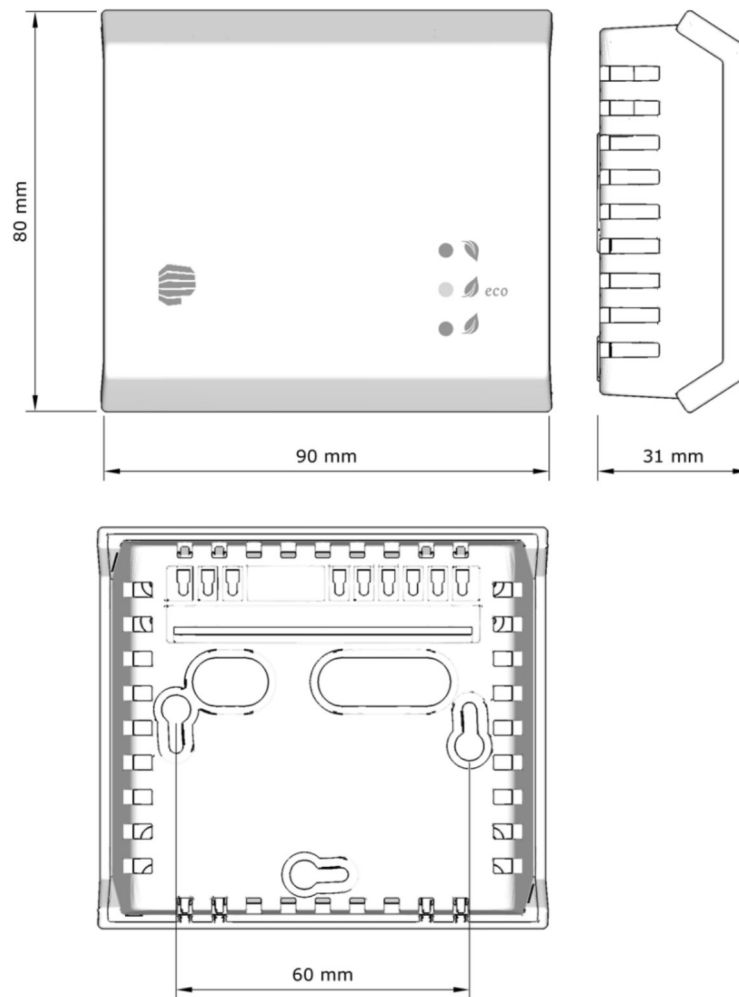

Sensor box colour	Front part white – RAL9016.	Back part white – RAL9016.
Note	Explanations of abbreviations and terms can be found on our website in the glossary section .	
Sensor fault indication	All three LEDs are permanently lit at the same time.	

Notes:

SAFETY NOTICE

- Before installation and first use, carefully read the full instruction manual, including safety warnings.
- The assembly, wiring and installation of the equipment may only be carried out by a person with the appropriate electrical qualifications.
- All supply lines must be de-energized during installation and wiring and secured against accidental switching on.
- Sensors must not be used as safety devices and their use is not for the protection of health, nor must they be used to protect persons, property or assets.
- The product is intended for indoor use only.
- Mechanical stress on the equipment such as dropping or impact should be avoided.
- Use the product only as specified in this user manual.

FOR HEALTHY INDOOR ENVIRONMENT AND ENERGY SAVING

Manufacturer: Protronix s.r.o.
Pardubicka 177, 537 01 Chrudim, Czech Republic

www.protronix.cz
www.protronix-sensors.com

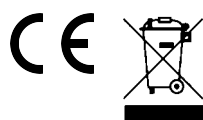

Dispose of the product at the end of its useful life in accordance with EU and national waste laws and directives.

The manufacturer reserves the right to make technical changes to improve the product, its features and functions without prior notice.